

# POWERTIP TECH. CORP.

DISPLAY DEVICES FOR BETTER ELECTRONIC DESIGN

## Specification For Approval

Customer : \_\_\_\_\_

Model Type : LCD Module

Sample Code : PG12232LRS-ANN-B-SA

Mass Production Code : \_\_\_\_\_

Edit : A

Customer Sign	Sales Sign	Approved By	Prepared By

# CONTENTS

## 1. SPECIFICATIONS

- 1.1 Features
- 1.2 Mechanical Specifications
- 1.3 Absolute Maximum Ratings
- 1.4 DC Electrical Characteristics
- 1.5 Optical Characteristics
- 1.6 Backlight Characteristics

## 2. MODULE STRUCTURE

- 2.1 Counter Drawing
- 2.2 Interface Pin Description
- 2.3 Timing Characteristics
- 2.4 Display Command



## 1. SPECIFICATIONS

### 1.1 Features

- Full dot-matrix structure with 122 dots \*32 dots
- 1/32 Duty, 1/5 bias
- STN LCD, positive
- Transflective LCD, gray
- 6 o'clock viewing angle
- 8 bits parallel data input
- Built-in LED backlight

### 1.2 Mechanical Specifications

- Outline dimension : 84.0mm(L)\*44.0mm(W)\*13.0mm max.(H)
- Viewing area : 60.5mm \*18.5mm
- Active area : 53.64mm \*15.64mm
- Dot size : 0.4mm \*0.45mm
- Dot pitch : 0.44mm \*0.49mm

### 1.3 Absolute Maximum Ratings

Item	Symbol	Conditions	Min.	Max.	Unit
Power supply Voltage	VDD	-	2.4	7.0	V
LCD drive Supply voltage	VDD-V0	-	3.5	13.0	V
Input voltage	VIN	-	-0.3	VDD+0.3	V
Operating temperature	TOPR	-	0	50	°C
Storage temperature	TSTG	-	-20	70	°C
Humidity*1	HD	-	-	90	%RH

### 1.4 DC Electrical Characteristics

VDD=5±0.5 V, VSS=0V, Ta=25°C

Item	Symbol	Condition	Min.	Typ.	Max.	Unit
Logic Supply voltage	VDD	-	4.5		5.5	V
“H” input voltage	VIH	-	2.2	-	VDD	V
“L” input voltage	VIL	-	0	-	0.8	V
Supply current	IDD	VDD=5V	-	-	2	mA
LCD driving voltage	VOP	VDD-V0	-	6.3	-	V



**POWERTIP TECHNOLOGY CORPORATION**  
 DISPLAY DEVICES FOR BETTER ELECTRONIC DESIGN

### 1.5 Optical Characteristics

1/32 duty, 1/5 bias,  $V_{opr}=6.3V$ ,  $T_a=25^{\circ}C$

Item	Symbol	Conditions	Min.	Typ.	Max	Reference
Viewing angle	$\theta$	$C \geq 2.0, \varnothing = 0^{\circ}C$	$35^{\circ}$	-	-	Notes 1 & 2
Contrast	C	$\theta = 5^{\circ}, \varnothing = 0^{\circ}$	2	3	-	Note 3
Response time(rise)	$t_r$	$\theta = 5^{\circ}, \varnothing = 0^{\circ}$	-	170ms	260ms	Note 4
Response time(fall)	$t_f$	$\theta = 5^{\circ}, \varnothing = 0^{\circ}$	-	250ms	380ms	Note 4

Note 1: Definition of angles  $\theta$  and  $\varnothing$

Note 2: Definition of viewing angles  $\theta_1$  and  $\theta_2$

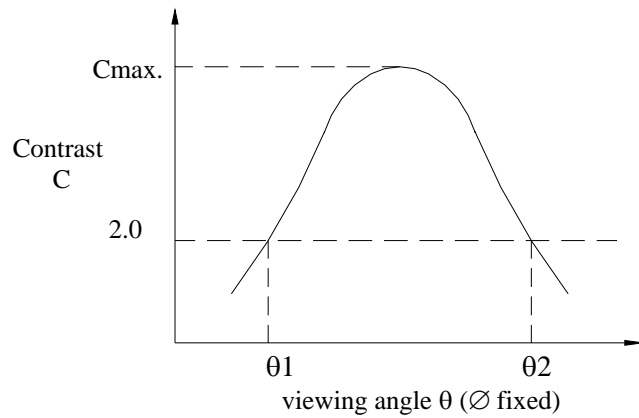
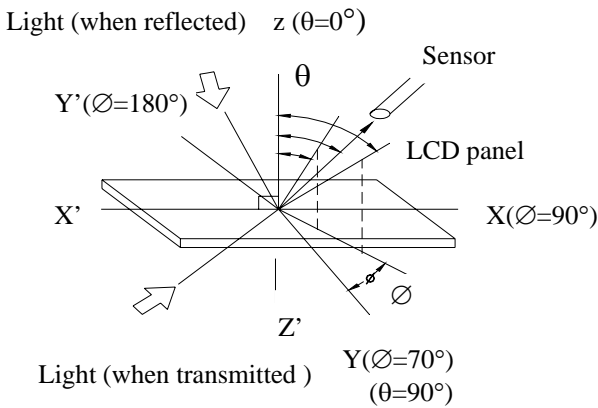

Note : Optimum viewing angle with the naked eye and viewing angle  $\theta$  at  $C_{max}$ . Above are not always the same

Note 3: Definition of contrast C

$$C = \frac{\text{Brightness (reflection) of unselected dot (B2)}}{\text{Brightness (reflection) of selected dot (B1)}}$$

Note 4: Definition of response time

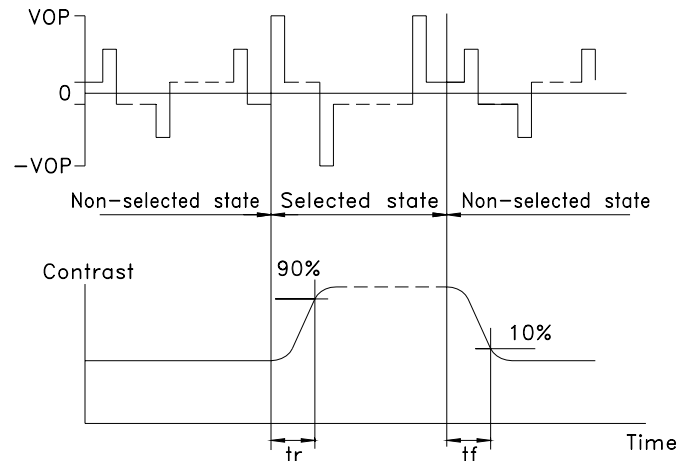
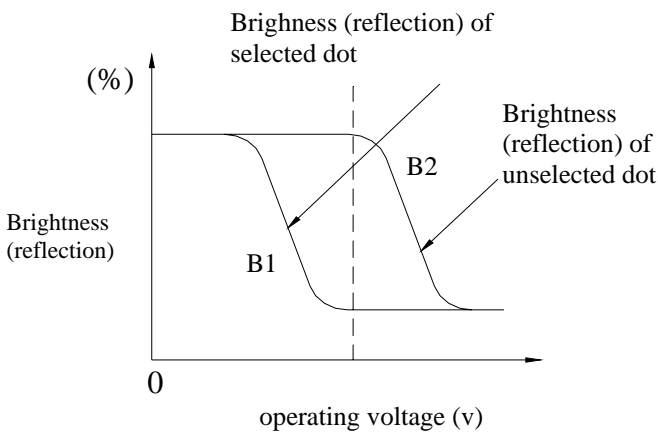

Note: Measured with a transmissive LCD panel which is displayed  $1\text{ cm}^2$

$V_{opr}$  : Operating voltage       $f_{FRM}$  : Frame frequency  
 $t_r$  : Response time (rise)       $t_f$  : Response time (fall)

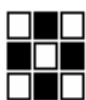

**POWERTIP TECHNOLOGY CORPORATION**  
 DISPLAY DEVICES FOR BETTER ELECTRONIC DESIGN

## 1.6 Backlight Characteristic

The LCD Module is backlight using a LED panel

- Maximum Ratings

Item	Symbol	Conditions	Min.	Max.	Unit
Forward current	IF	TA=25°C	-	300	mA
Reverse voltage	VR	TA=25°C	-	8	V
Power dissipation	PO	TA=25°C	-	1.38	W
Operating Temperature	TOPR	-	-20	70	°C
Storage temperature	TSTG	-	-40	80	°C

- Electrical Ratings

Item	Symbol	Condition	Min.	Typ.	Max.	Unit
Forward voltage	VF	IF=120mA	-	4.2	4.6	V
Reverse current	IR	VR=8V	-	-	0.2	mA
Luminous intensity	IV	IF=120mA	160	200	-	cd/m <sup>2</sup>
Wavelength	$\lambda p$	IF=120mA	565	-	571	nm
Color	Yellow Green					

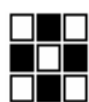

## 2. MODULE STRUCTURE

### 2.1 Counter Drawing

\*See Appendix

### 2.2 Interface Pin Description

Pin No	Symbol	Function
1	Vss	Signal ground (GND)
2	Vdd	Power supply for logic (+5V)
3	Vee	Operating voltage for LCD (variable)
4	A0	“L”=DB0 to DB7 are display control data “H”=DB0 to DB7 are display data
5	CS1	Chip enable active “L”, segment 0~segment 61
6	CS2	Chip enable active “L”, segment 62~segment 98
7	CL	Clock input 2KHZ
8	E	Enable signal
9	$R/\overline{W}$	Data read & write
10-17	DB0~DB7	8 bit data bus
18	RES	“L” level=80 series MPU interface “H” level=68 series MPU interface
19	A	LED backlight drive voltage V+
20	K	LED backlight drive voltage ground

Contrast Adjust

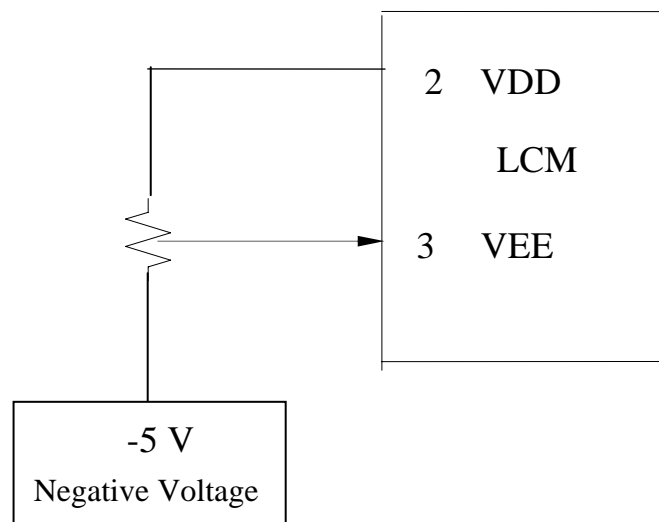

## 2.3 Timing Characteristics

### • MPU Bus Read/Write I (80-family MPU)

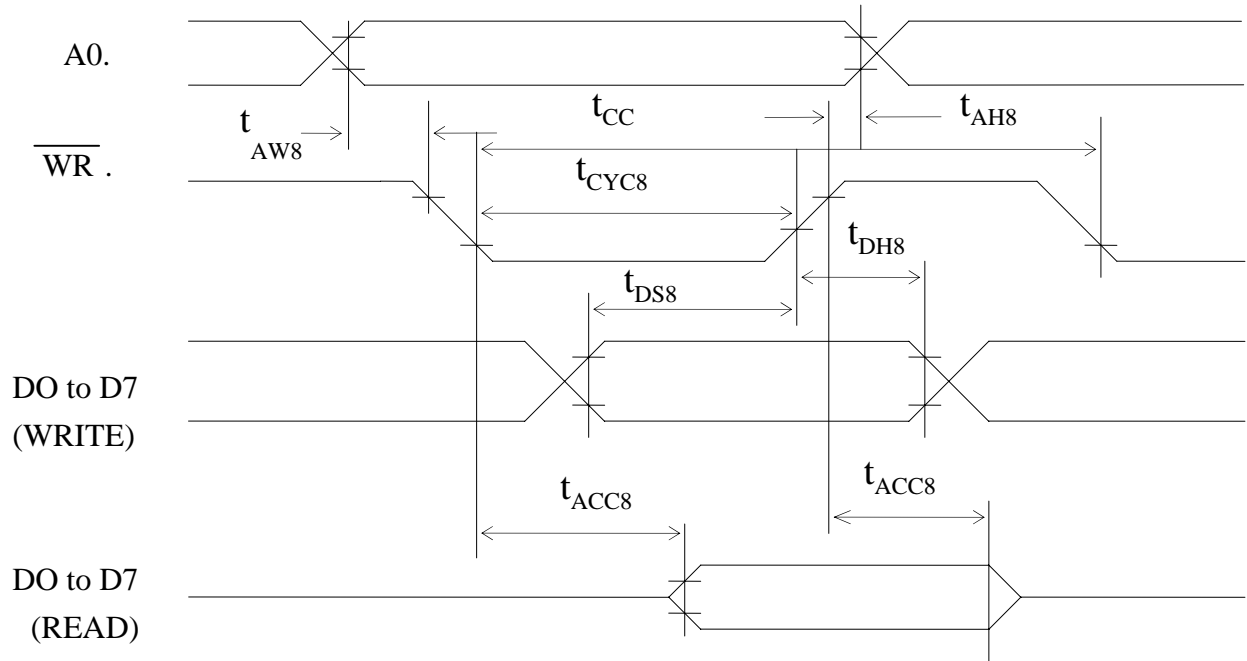

### • MPU Bus Read/Write II (68-family MPU)

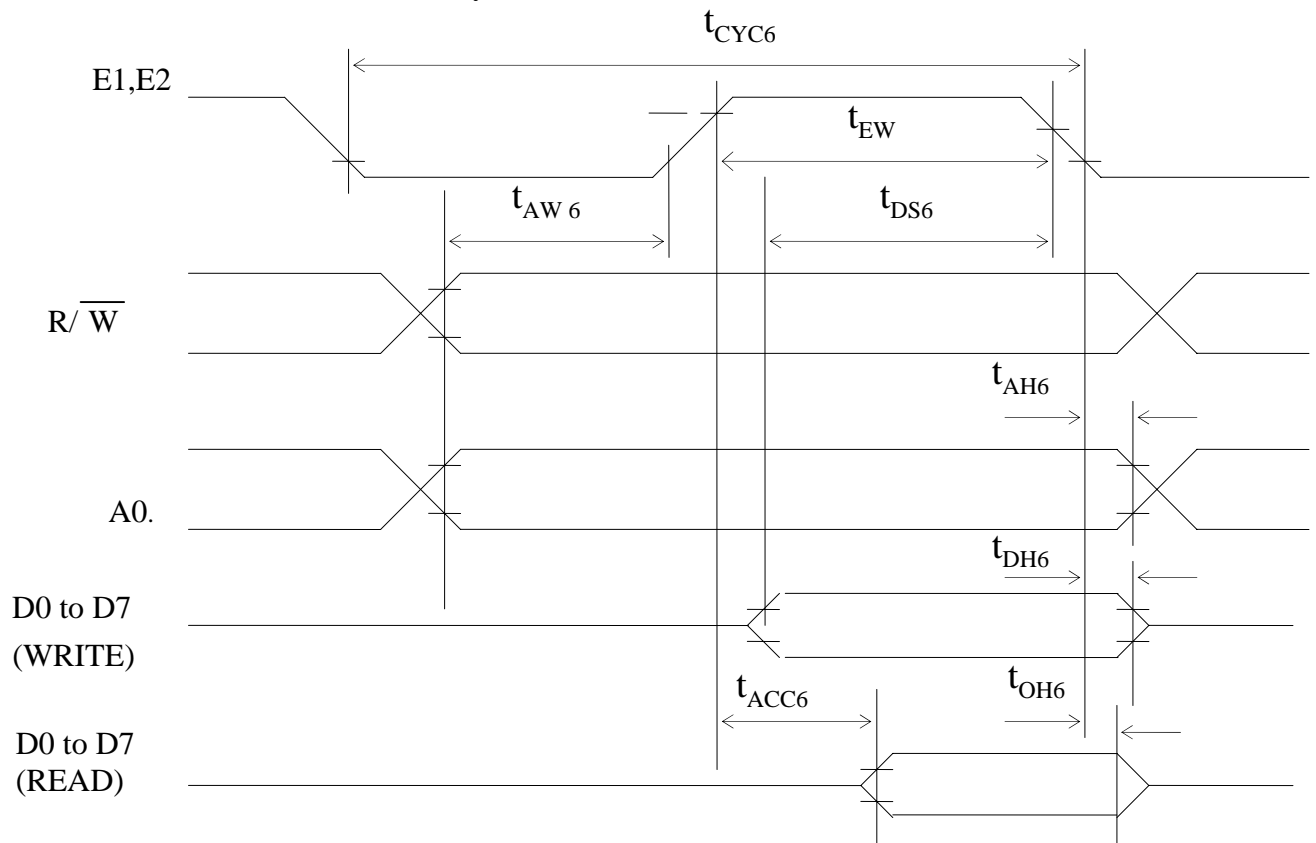

## •MPU Bus Read/Write I (80-family MPU)

VDD=+5V±10%, VSS=0V, Ta=25°C

Item	Symbol	Conditions	Min.	Max.	Unit
Address hold time	tAH8	-	10	-	ns
Address setup time	tAW8	-	20	-	ns
System cycle time	tCYC8	-	1000	-	ns
Control pulse width	tCC	-	200	-	ns
Data setup time	tDS8	-	80	-	ns
Data hold time	tDH8	-	10	-	ns
RD access time	tACC8	CL=100 PF	-	90	ns
Output disable time	tCH8		10	90	ns

## •MPU Bus Read/Write II (68-family MPU)

VDD=+5V±10% , VSS=0V, Ta=25°C

Item	Symbol	Conditions	Min.	Max.	Unit
System cycle time	teyc6	-	1000	-	ns
Address setup time	tAW6	-	20	-	ns
Address hold time	tAH6	-	10	-	ns
Data hold time	tDS6	-	80	-	ns
Data hold time	tDH6	-	10	-	ns
Output disable time	tOH6	CL=100 PF	10	60	ns
Access time	tACC6		-	90	ns
Enable pulse width	Read	tEW	100	-	ns
	Write	tEW	80	-	ns



**POWERTIP TECHNOLOGY CORPORATION**

DISPLAY DEVICES FOR BETTER ELECTRONIC DESIGN



## 2.4 Display Command

### COMMAND

#### Summary

Command	Code											Function	
	A0	RD E	R/W	D7	D6	D5	D4	D3	D2	D1	D0		
Display On/Off	0	1	0	1	0	1	0	1	1	1	0/1	Turns display on or off. 1: ON, 0:OFF	
Display start line	0	1	0	1	1	0	Display start address(o to 31)				0	Specifies RAM line corresponding to top line of display.	
Set page address	0	1	0	1	0	1	1	1	0	Page(o to 3)		Set s display RAM page in page address register.	
Set column (segment) address	0	1	0	0	Column address (o to 79)							0	Sets display RAM column address in column address register.
Read status	0	0	1	Busy	ADC	ON/OFF	Reset	0	0	0	0	Reads the following status: BUSY        1: Busy 0: Ready ADC         1: CW output 0: CCW output ON/OFF     1: Display off 0: Display on RESET      1: Being reset 0: Normal	
Write display data	1	1	0	Write data								0	Write data from data bus into display RAM.
Read display data	1	0	1	Read data								0	Reads data from display RAM onto data bus.
Select ADC	0	1	0	1	0	1	0	0	0	0	0/1	0: CW output, 1:CCW output	
Statis drive ON/OFF	0	1	0	1	0	1	0	0	1	0	0/1	Selects static driving operation. 1:static drive, 0: Normal driving	
Select duty	0	1	0	1	0	1	0	1	0	0	0/1	Selects LCD duty cycle 1: 1/32, 0: 1/16	
Read-Modify-Write	0	1	0	1	1	1	0	0	0	0	0	Read-modify-write ON	
End	0	1	0	1	1	1	0	1	1	1	0	Read-modify-write OFF	
Reset	0	1	0	1	1	1	0	0	0	1	0	Software reset	

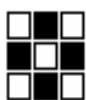

**POWERTIP TECHNOLOGY CORPORATION**

**DISPLAY DEVICES FOR BETTER ELECTRONIC DESIGN**

### Command description

Table 1 is the command table. The SED1520 series identifies a data bus using a combination of A0 and R/ $\overline{w}$  (RD or  $\overline{WR}$ ) signals. As the MPU translates a command in the internal timing only (independent from the external clock). Its speed is very high. The busy check is usually not required.

### Display ON/OFF

A0	$\frac{E}{RD}$	$\frac{R/\overline{w}}{\overline{WR}}$	D7	D6	D5	D4	D3	D2	D1	D0	
0	1	0	1	0	1	0	1	1	1	D	AEH,AFH

This command turns the display on and off.

- D=1: Display ON
- D=0: Display OFF

### Display Start Line

This command specifies the line address shown in Figure 1 and indicates the display line that corresponds to COM0. The display area begins at the specified line address and continues in the line address increment direction. This area having the number of lines of the specified display duty is displayed. If the line address is changed dynamically by this command the vertical smooth scrolling and paging can be used.

A0	$\frac{E}{RD}$	$\frac{R/\overline{w}}{\overline{WR}}$	D7	D6	D5	D4	D3	D2	D1	D0	
0	1	0	1	1	0	A4	A3	A2	A1	A0	COH,DFH

This command loads the display start line register.

A4	A3	A2	A1	A0	Line Address
0	0	0	0	0	0
0	0	0	0	1	1
		⋮			⋮
		⋮			⋮
1	1	1	1	1	31

See Figure 1.

### Set Page Address

This command specifies the page address that corresponds to the low address of the display data RAM when it is accessed by the MPU. Any bit of the display data RAM can be accessed when its page address and column address are specified. The display status is not changed even when the page address is changed.

A0	$\frac{E}{RD}$	$\frac{R/\overline{w}}{\overline{WR}}$	D7	D6	D5	D4	D3	D2	D1	D0	
0	1	0	1	0	1	1	1	0	A1	A0	B8H,BBH



**POWERTIP TECHNOLOGY CORPORATION**

DISPLAY DEVICES FOR BETTER ELECTRONIC DESIGN

This command loads the page address register.

A1	A0	Page
0	0	0
0	1	1
1	0	2
1	1	3

### Set column Address

This command specifies a column address of the display data RAM. When the display data RAM is accessed by the MPU continuously, the column address is incremented by 1 each time it is accessed from the set address. Therefore, the MPU can access to data continuously. The column address stops to be incremented at address 80, and the page address is not changed continuously.

A0	E	R/ $\overline{W}$	D7	D6	D5	D4	D3	D2	D1	D0	
	$\overline{RD}$	$\overline{WR}$									
0	1	0	0	A6	A5	A4	A3	A2	A1	A0	00H,4FH

This command loads the column address register.

A6	A5	A4	A3	A2	A1	A0	Line Address
0	0	0	0	0	0	0	0
0	0	0	0	0	0	1	1
			⋮				⋮
			⋮				⋮
1	0	0	1	1	1	1	79

### Read Status

A0	E	R/ $\overline{W}$	D7	D6	D5	D4	D3	D2	D1	D0
	호류	$\overline{WR}$								
0	0	1	BUSY	ADC	ON/OFF	RESE T	0	0	0	0

Reading the command I/O register (A0=0) yields system status information.

- The busy bit indicates whether the driver will accept a command or not.  
Busy=1: The driver is currently executing a command or is resetting. No new command will be accepted.  
Busy=0: The driver will accept a new command.
- The ACD bit indicates the way column addresses are assigned to segment drivers.  
ADC=1: Normal. Column address n → segment driver n.  
ADC=0: Inverted. Column address 79-u → segment driver u.
- The ON/OFF bit indicates the current status of the display.

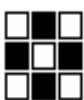

**POWERTIP TECHNOLOGY CORPORATION**

DISPLAY DEVICES FOR BETTER ELECTRONIC DESIGN

It is the inverse of the polarity of the display ON/OFF command.

ON/OFF=1: Display OFF

ON/OFF=0: Display ON

- The RESET bit indicates whether the driver is executing a hardware or software reset or if it is in normal operating mode.

RESET=1: Currently executing reset command.

RESET=0: Normal operation

### Write Display Data

A0	$\overline{E}$ RD	$\overline{R/\overline{W}}$ WR	D7	D6	D5	D4	D3	D2	D1	D0
1	1	0	Write data							

Writes 8-bit of data into the display data RAM, at a location specified by the contents of the column address and page address registers and then increments the column address register by one.

### Read Display Data

A0	$\overline{E}$ RD	$\overline{R/\overline{W}}$ WR	D7	D6	D5	D4	D3	D2	D1	D0
1	0	1	Read data							

Reads 8-bits of data from the data I/O latch, updates the contents of the I/O latch with display data from the display data RAM location specified by the contents of the column address and page address registers and then

increments the column address register.

After loading a new address into the column address register one dummy read is required before valid data is obtained.

### Select ADC

A0	$\overline{E}$ RD	$\overline{R/\overline{W}}$ WR	D7	D6	D5	D4	D3	D2	D1	D0
0	1	0	1	0	1	0	0	0	0	D

A0H, A1H

This command selects the relationship between display data RAM column addresses and segment drivers.

D=1: SEG0 ← column address 4FH,...(inverted)

D=0: SEG0 ← column address 00H,...(normal)

This command is provided to reduce restrictions on the placement of driver ICs and routing of traces during printed circuit board design. See Figure 1 for a table of segments and column addresses for the two values of D.



**POWERTIP TECHNOLOGY CORPORATION**

**DISPLAY DEVICES FOR BETTER ELECTRONIC DESIGN**

**Static Drive ON/OFF**

A0	$\overline{\text{RD}}$	$\overline{\text{WR}}$	D7	D6	D5	D4	D3	D2	D1	D0	
0	1	0	1	0	1	0	0	1	0	D	A4H, ,A5H

Forces display on and all common outputs to be selected.

D=1: Static drive on

D=0: Static drive off

**Select Duty**

A0	$\overline{\text{RD}}$	$\overline{\text{WR}}$	D7	D6	D5	D4	D3	D2	D1	D0	
0	1	0	1	0	1	0	1	0	0	D	A8H, ,A9H

This command sets the duty cycle of the LCD drive .

SED1520

D=1: 1/32 duty cycle

D=0: 1/16 duty cycle

**Read-Modify-Write**

A0	$\overline{\text{RD}}$	$\overline{\text{WR}}$	D7	D6	D5	D4	D3	D2	D1	D0	
0	1	0	1	1	1	0	0	0	0	0	EOH

This command defeats column address register auto-increment after data reads. The current contents of the column address register are saved. This mode remains active until an End command is received.

- Operation sequence during cursor display

When the End command is entered, the column address is returned to the one used during input of Read-Modify-Write command. This function can reduce the load of MPU when data change is repeated at a specific display area (such as cursor blinking).

\* Any command other than Data Read or Write can be used in the Read-Modify-Write mode. However, the Column Address Set command cannot be used.



**POWERTIP TECHNOLOGY CORPORATION**

DISPLAY DEVICES FOR BETTER ELECTRONIC DESIGN

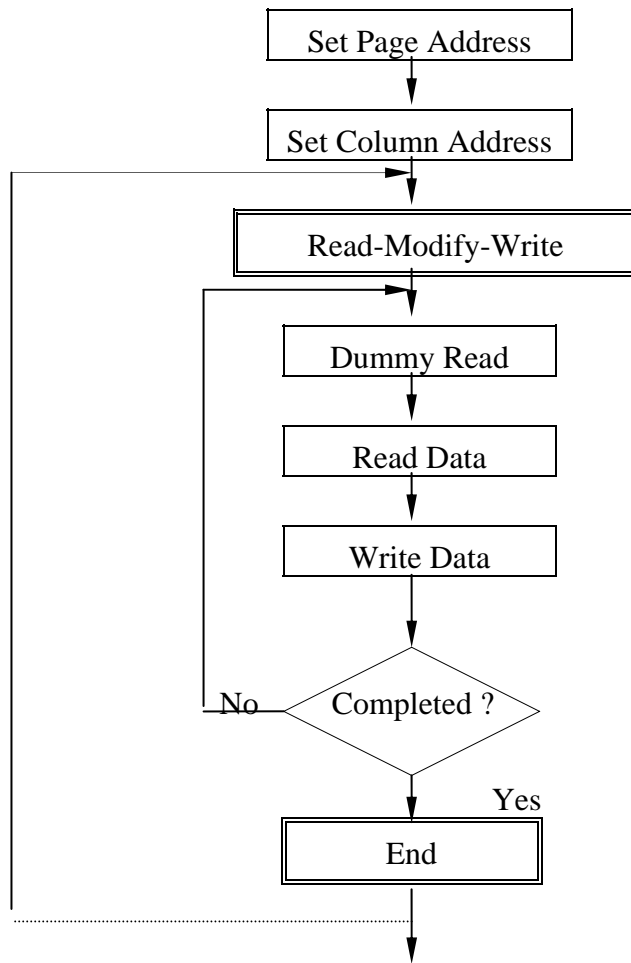

**End**

A0	$\overline{E}$ RD	$\overline{R/\overline{W}}$ WR	D7	D6	D5	D4	D3	D2	D1	D0	
0	1	0	1	1	1	0	1	1	1	0	EEH

This command cancels read-modify-write mode and restores the contents of the column address register to their value prior to the receipt of the Read-Modify-Write command.

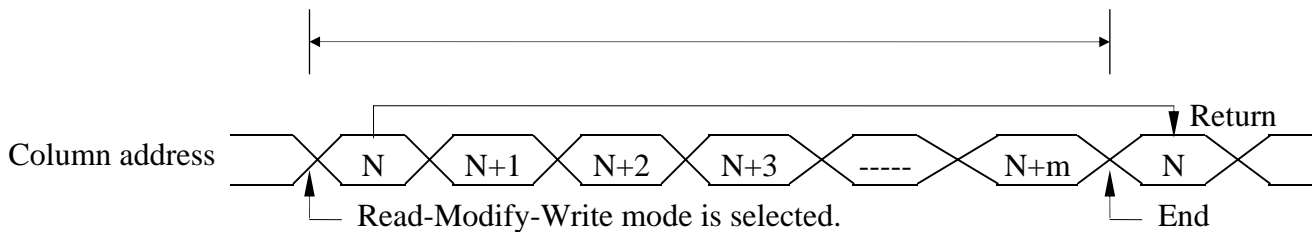

**Reset**

A0	$\overline{\text{RD}}$	$\overline{\text{R/W}}$	D7	D6	D5	D4	D3	D2	D1	D0
0	1	0	1	1	1	0	0	0	1	0

E2H

This command clears

- the display start line register.
- and set page address register to 3 page.

It does not affect the contents of the display data RAM.

When the power supply is turned on, a Reset signal is entered in the RES pin. The Reset command cannot be used instead of this Reset signal.

Figure 1

Page address	Data	Line address	Command output
D1,D2=0,0	D0	0011	COM 0
	D1	01	COM 1
	D2	02	COM 2
	D3	03	COM 3
	D4	04	COM 4
	D5	05	COM 5
	D6	06	COM 6
	D7	07	COM 7
0,1	D0	08	COM 8
	D1	09	COM 9
	D2	0A	COM 10
	D3	0B	COM 11
	D4	0C	COM 12
	D5	0D	COM 13
	D6	0E	COM 14
	D7	0F	COM 15
1,0	D0	10	COM 16
	D1	11	COM 17
	D2	12	COM 18
	D3	13	COM 19
	D4	14	COM 20
	D5	15	COM 21
	D6	16	COM 22
	D7	17	COM 23
1,1	D0	18	COM 24
	D1	19	COM 25
	D2	1A	COM 26
	D3	1B	COM 27
	D4	1C	COM 28
	D5	1D	COM 29
	D6	1E	COM 30
	D7	1F	COM 31

Column address	Line address	Command output
D0="0"	D0="0"	3A
D0="1"	D0="0"	3B
D0="0"	D0="1"	3C
D0="1"	D0="1"	3C

SEG pin	Line address	Command output
SEG 0	58	00
1	59	01
2	60	02
3		03
4		04
5		05
6		06
7		07

**Display Data RAM Addressing**

- (122 \* 32) is consisted of 2(61 \* 32), CS1 enable left (61 \* 32)



**POWERTIP TECHNOLOGY CORPORATION**

**DISPLAY DEVICES FOR BETTER ELECTRONIC DESIGN**

CS2 enable

right (61 \*32)

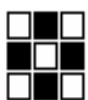

*POWERTIP TECHNOLOGY CORPORATION*  
DISPLAY DEVICES FOR BETTER ELECTRONIC DESIGN